

Ultra High-Speed Angular Contact Ball Bearings

BNR Series Ultra High-Speed Angular Contact Ball Bearings-150BNR19H

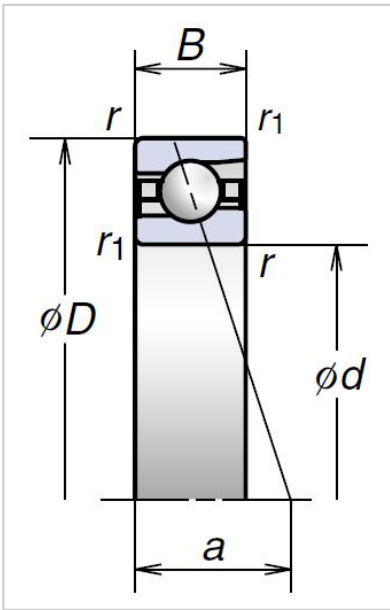

Bearing NO.	150BNR19H
Boundary Dimensions (mm)	
d	150
D	210
B	28
r (min.)	2
r1 (min.)	1
Basic Load Ratings (kN)	
Cr (Dynamic)	77
C0r (Static)	78.5
Permissible Axial Load (1) (kN)	75
Effective Load Center (mm) a	43.2
Sealed Design	-
Limiting Speeds (2) (min ⁻¹)	
Grease	10000
Oil	15600
Mass (kg)	2.139