

Ultra High-Speed Angular Contact Ball Bearings

BNR Series Ultra High-Speed Angular Contact Ball Bearings-110BNR19S

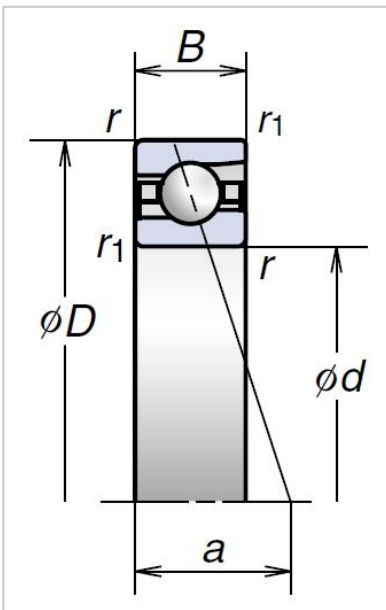

Bearing NO.	110BNR19S
Boundary Dimensions (mm)	
d	110
D	150
B	20
r (min.)	1.1
r1 (min.)	0.6
Basic Load Ratings (kN)	
Cr (Dynamic)	39
C0r (Static)	38
Permissible Axial Load (1) (kN)	55.5
Effective Load Center (mm) a	31.1
Sealed Design	-
Limiting Speeds (2) (min ⁻¹)	
Grease	10800
Oil	15400
Mass (kg)	0.838